

OPDEC Network Trace Tool

Version 2011



Summary: The OPDEC Network Trace tool allows a user to easily identify all of the activities leading up to one or more points in the schedule. This is used by planners to ensure that tasks are linked via logic (predecessor / successor) links to another milestone or task in the schedule. The user identifies an activity or milestone (or multiples) and the tool identifies all predecessors to that point or points. The tool also has a reporting feature which identifies the existence redundant links within the schedule

Installation and Activation.....	2
Settings.....	4
Operation.....	5
Trace Back	7
Single Event	7
Multiple Events, First Reference	8
Multiple Events, All References	9
Trace Forward.....	10
Single Event	10
Multiple Events, Last Reference	11
Multiple Events, All References	12
Trace Between	13
Redundant Links Report	14

Installation and Activation

Follow the instructions seen while running the installation executable file NetworkTrace2011.exe.

Requirements:

- Microsoft Project 2003/2007/2010
- Microsoft Windows 2000/XP/Vista/Win 7



- 1) Open Microsoft Project
- 2) Click on “Network Trace” in the OPDEC toolbar (Figure 1)

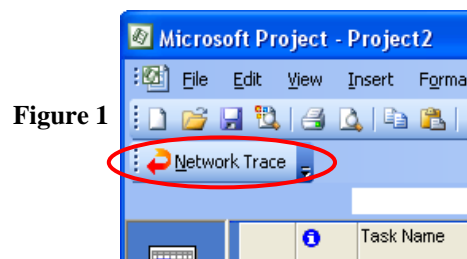

Figure 1

- 3) Once you first start-up the Network Trace tool, you will be prompted to activate the software. (Figure 2). You may choose the “Activate Later” button for up to 30 days before the software is disabled.

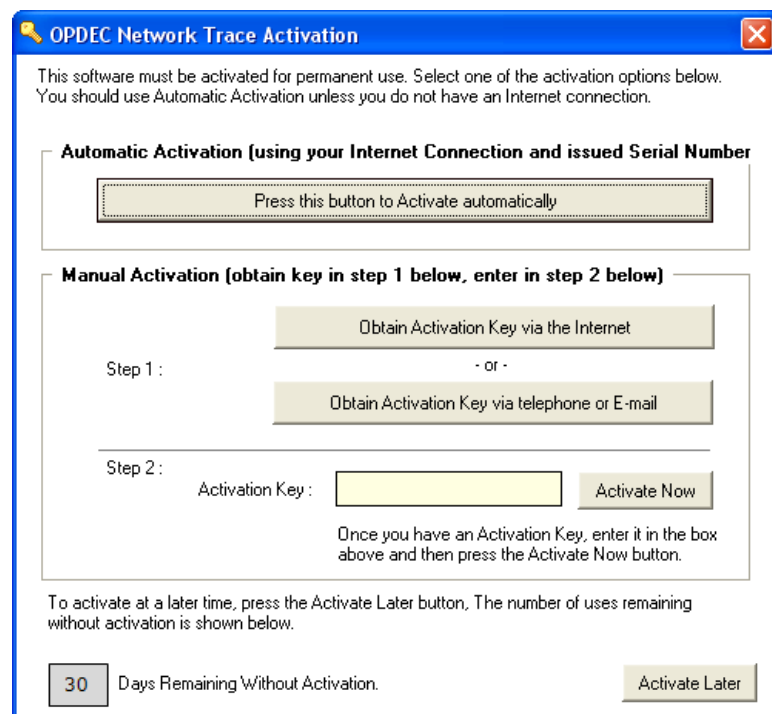

Figure 2

- a. Automatic Activation - If your computer is connected to the Internet, then you can use this easy option.
- i. Click **Press this button to activate automatically**.
 - ii. Enter your name, email, company name, and the serial number that you were issued. Then click OK. (Figure 2a)
 - iii. If your firewall prevents this automated action, try using one of the Manual Activation procedures as described below.

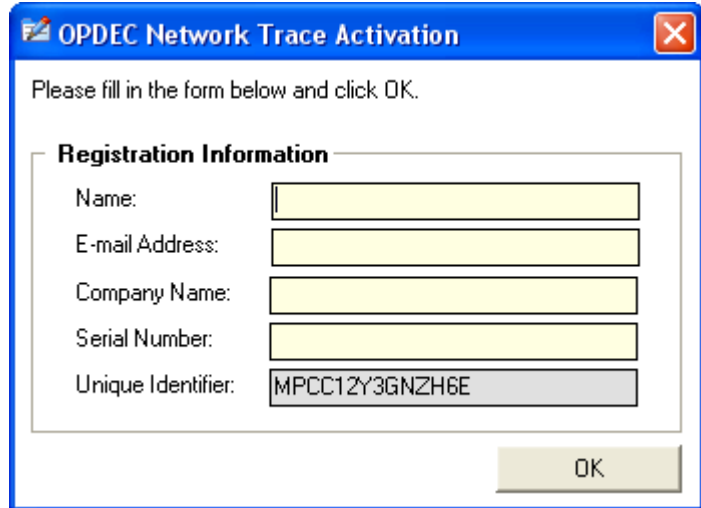

Figure 2a

- b. Manual Internet Activation - If your computer is connected to the Internet, then you can manually retrieve an Activation Key from the OPDEC web site.
- i. Click **Obtain Activation Key via the Internet**.
 - ii. Your internet browser will launch, automatically go to the OPDEC web site, and display your Activation Key.
 - iii. Enter the Activation Key in the Activation Key slot, as shown in Figure 2.
 - iv. Press Activate Now.
- c. Manual Phone/Email Activation – If the two prior methods of activation are unsuccessful, click **Obtain Activation Key via telephone or E-mail**.
- i. Send us an email (support@opdec.com) or contact our support desk for more help. (Figure 2b)

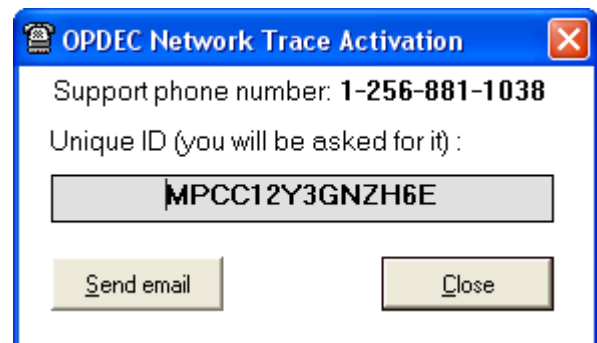

Figure 2b

Settings

- The settings for the tool are located can be accessed by clicking the “Tools” menu and then selecting the “Settings” option.
 1. General Settings
 1. Major Events Field - Select the field where you are identifying the major events.
 2. Trace Code Field – This location is updated with the trace code requested during the trace routines. This should be an empty text field in your project file
 2. Total Slack Trace Settings
 1. Calculated Float Storage Field – This field is used to store the float for use in identifying the event that impacts the activity the most. This is utilized when using the “Total Slack Trace” option from the main screen. This should be an empty text field in your project file.
 2. Event Target Date Field – This is the field specifying the date in which the event must complete by.
 3. Text Field Not Used - This is simply any text field (other than those already defined in previous settings) that is not currently utilized in the schedule. This field is used to store information by the tool to complete the Total Slack trace process.

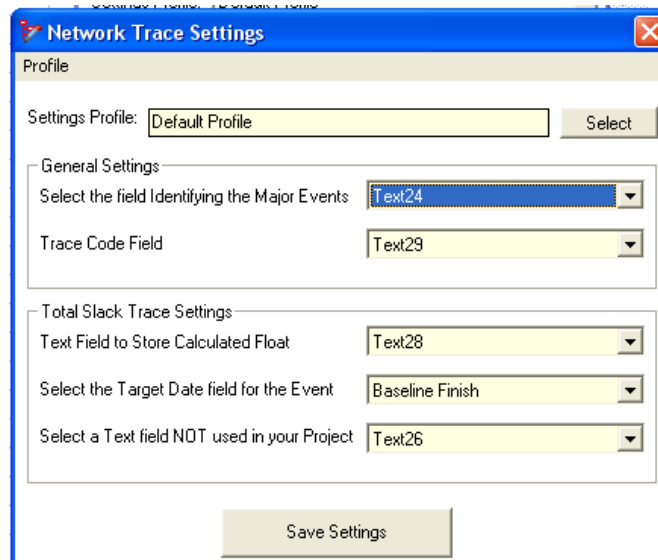
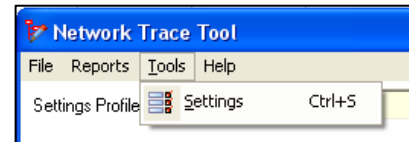

Figure 3

Profiles

- Starting in version 2011, multiple combinations of settings can be saved and retrieved. The currently selected profile name is displayed at the top of each form. To switch profiles, either select a profile name from the dropdown box on the main form or click the **Select** button on the Settings form.

To create a new profile:

Enter the desired settings and select **Profile >> Save Profile As**

To delete a profile

Select **Profile >> Delete**

Save Settings **performs the same function as the Save button, Exit closes the form without saving the changes**

Profile		
	Save Settings	Ctrl+S
	Save Profile As	Ctrl+A
	Delete	Ctrl+D
	Exit	Ctrl+E

Operation

- Redundant Link Report – Redundant links are identified when one activity is directly and indirectly to another (see Figure 11 for an example). This process generates a report in Excel depicting the redundant links identified in the schedule. There are 2 identification modes in evaluating a schedule for redundant links (Figure 4):
 - Limited – In this mode, a sampling of the schedule is performed in attempt to identify a maximum of 100 redundant activities.
 - Full – In this mode, the entire schedule is evaluated and a full report of all redundant links is provided. This mode of operation will take longer to process.

Remove Links – Checking this option will remove any identified redundant link if doing so does not change the dates of either activity.

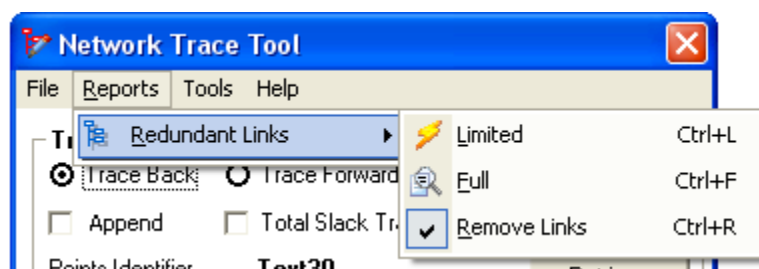

Figure 4

- Trace Forward/Back
 1. Trace Back and Trace Forward options - Select the option button for the trace direction you wish to perform.
 2. Append – When not checked, the process codes each activity with the first (in date order) event supported. So as in Figure 5, if a TIM activity is in the same path as the SRR activity, the trace would only code those activities with TIM. Conversely, checking this box will code those common activities with both TIM and SRR.
 3. Points Identifier - This is an option where you can specify a field that contains all the activities you want to trace from/to. Select that field and press “Retrieve” to auto populate the list with those items that you want to trace.
 4. ID and Trace Code Fields – With these you can manually enter the activities you want to trace. Enter the activity ID and then a trace code of your choosing before selecting the ‘Add’ button. The “Delete” button is used to remove items from the list box.
 5. Finally, select the “Run Trace Backward/Forward” to execute the tracing routine for the items entered.
 6. When completed, the Trace Code Field can be used within the schedule to filter the activities identified by the trace. (Fig 6-13)
- Trace Between
 1. Enter the starting and ending ID’s of the activities you want to trace between.
 2. Select the “Run Trace Between” button to execute the process.
 3. When completed, the schedule will be filtered showing the user all activities that flow within the start ID and ending ID (Fig 12).
- Total Slack Trace
 1. The total slack trace option directs the tool to trace the actual total slack between predecessors.
 2. The total slack trace can only be run when doing a Trace Back.

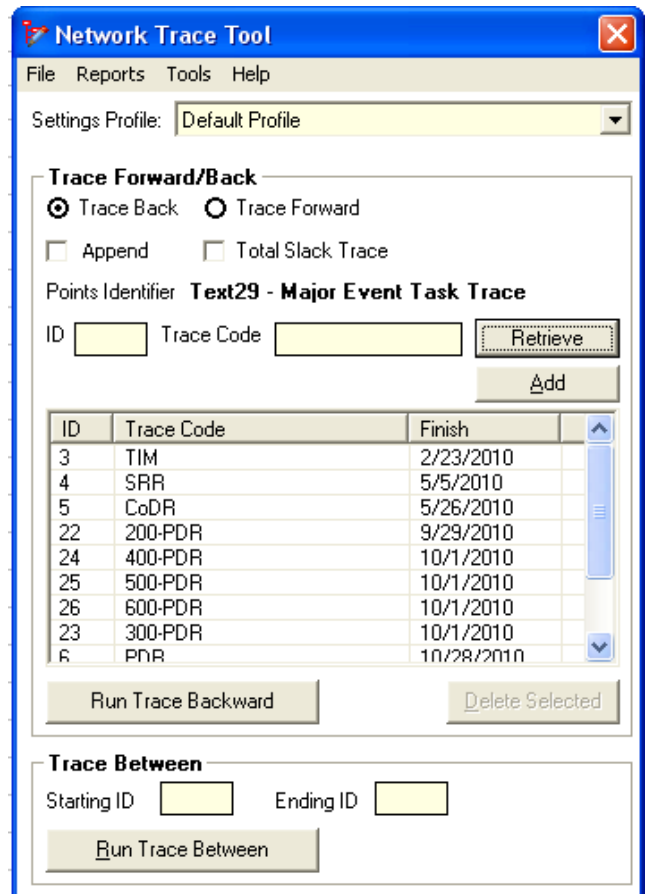

Figure 5

Updates to the Network Trace tool are available through the ‘Help’ menu as an update becomes available.

Trace Back

Single Event

- Trace back identifying all predecessors from a single event

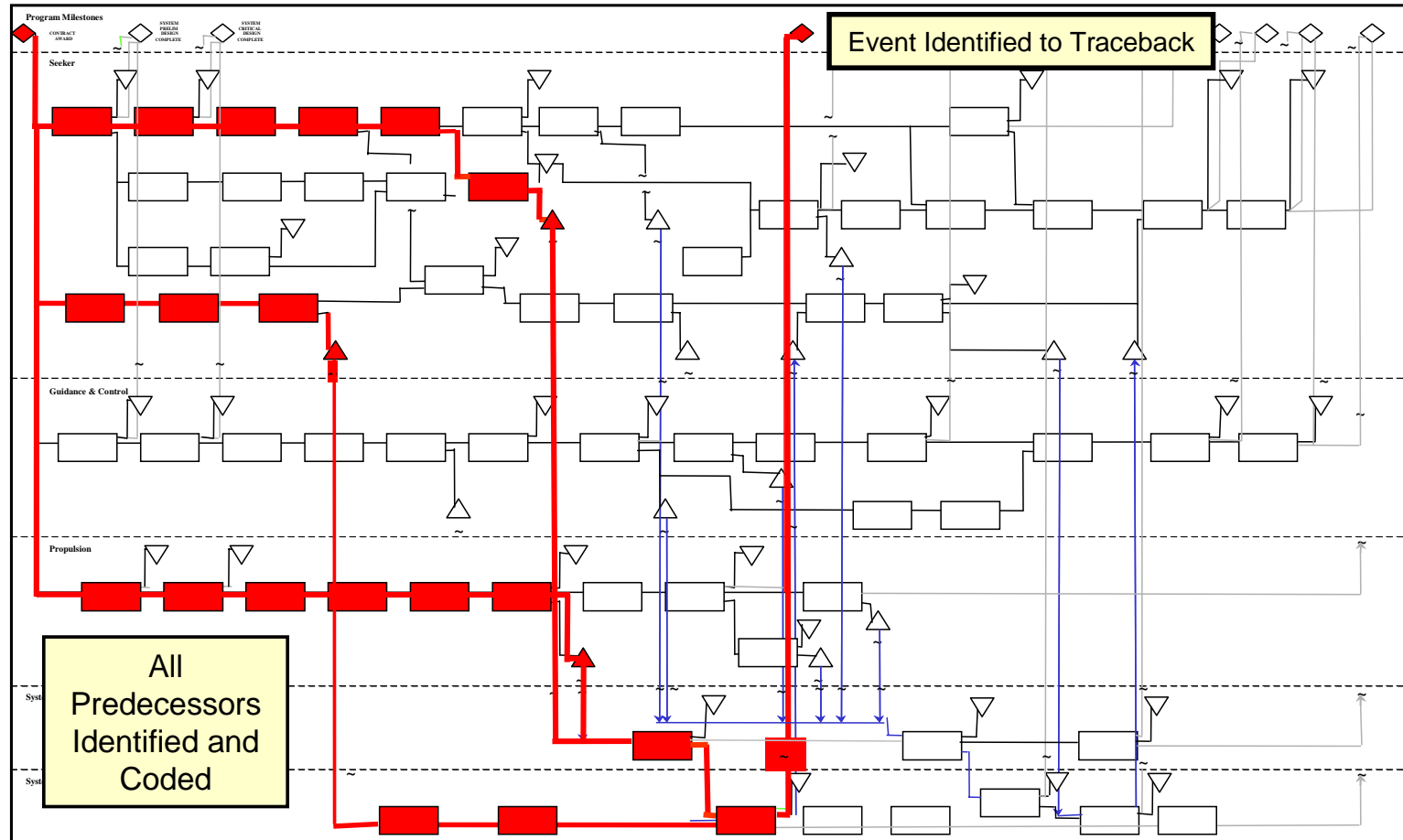

Figure 6

Multiple Events, First Reference

- Trace back identifying all predecessors from a multiple events
- Process codes each predecessor with the first (in date order) event supported
- Able to review tasks not coded to determine correct link to support an event and that all tasks support event milestones

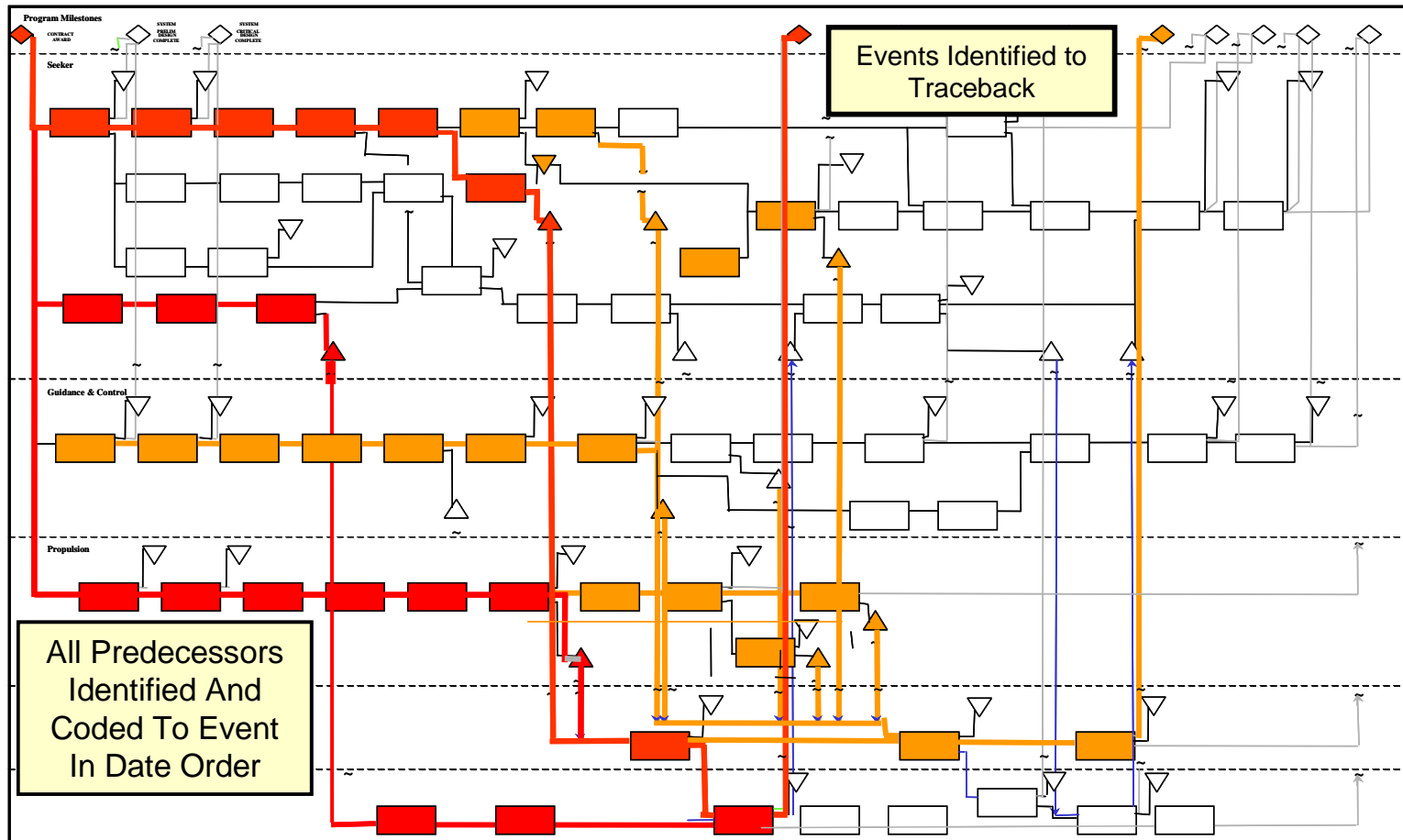

Figure 7

Multiple Events, All References

- Trace back identifying all predecessors from a multiple events
- Process codes each predecessor with the all events supported
- Able to review tasks not coded to determine correct link to support an event

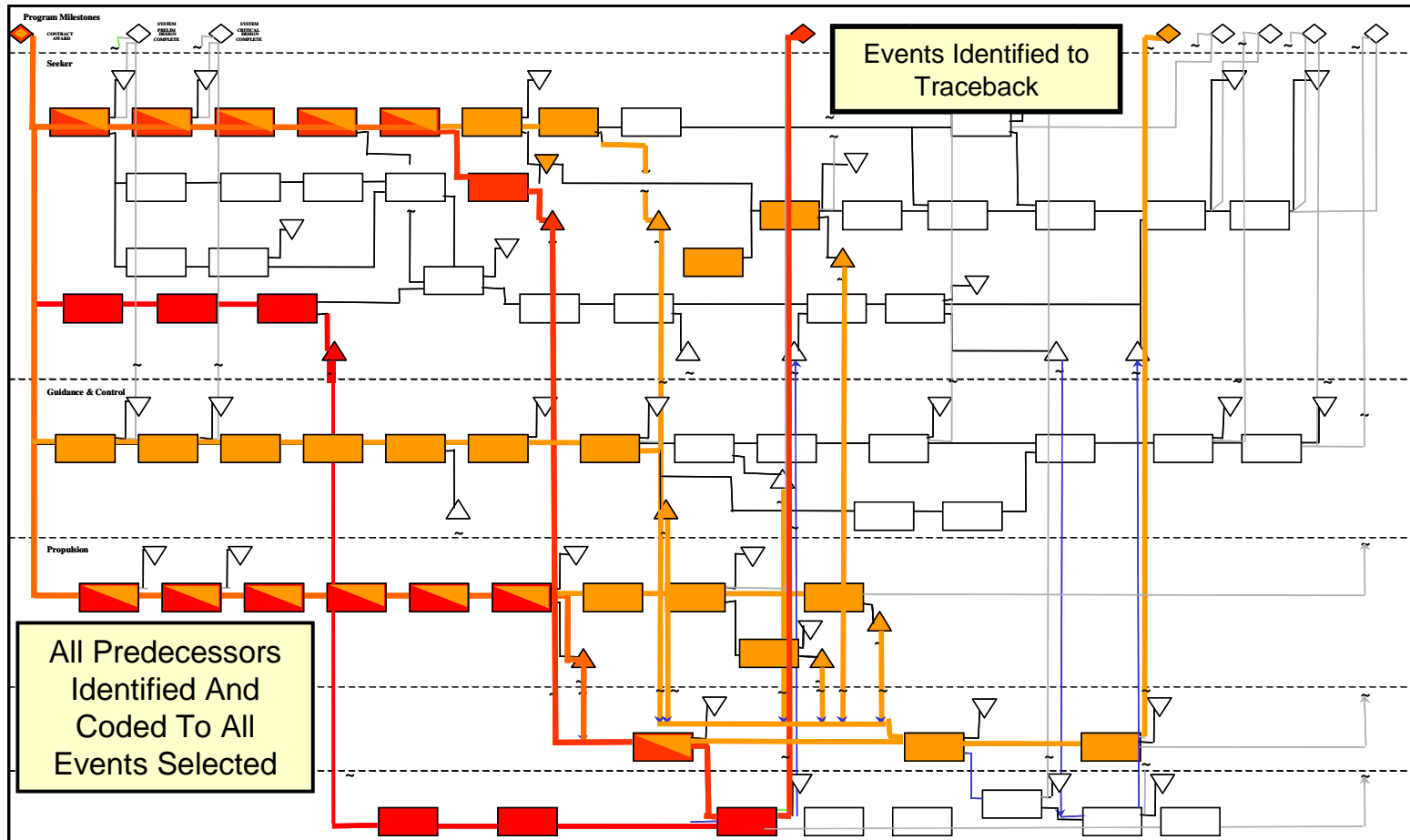

Figure 8

Trace Forward

Single Event

- Trace forward identifying all successors from a single event

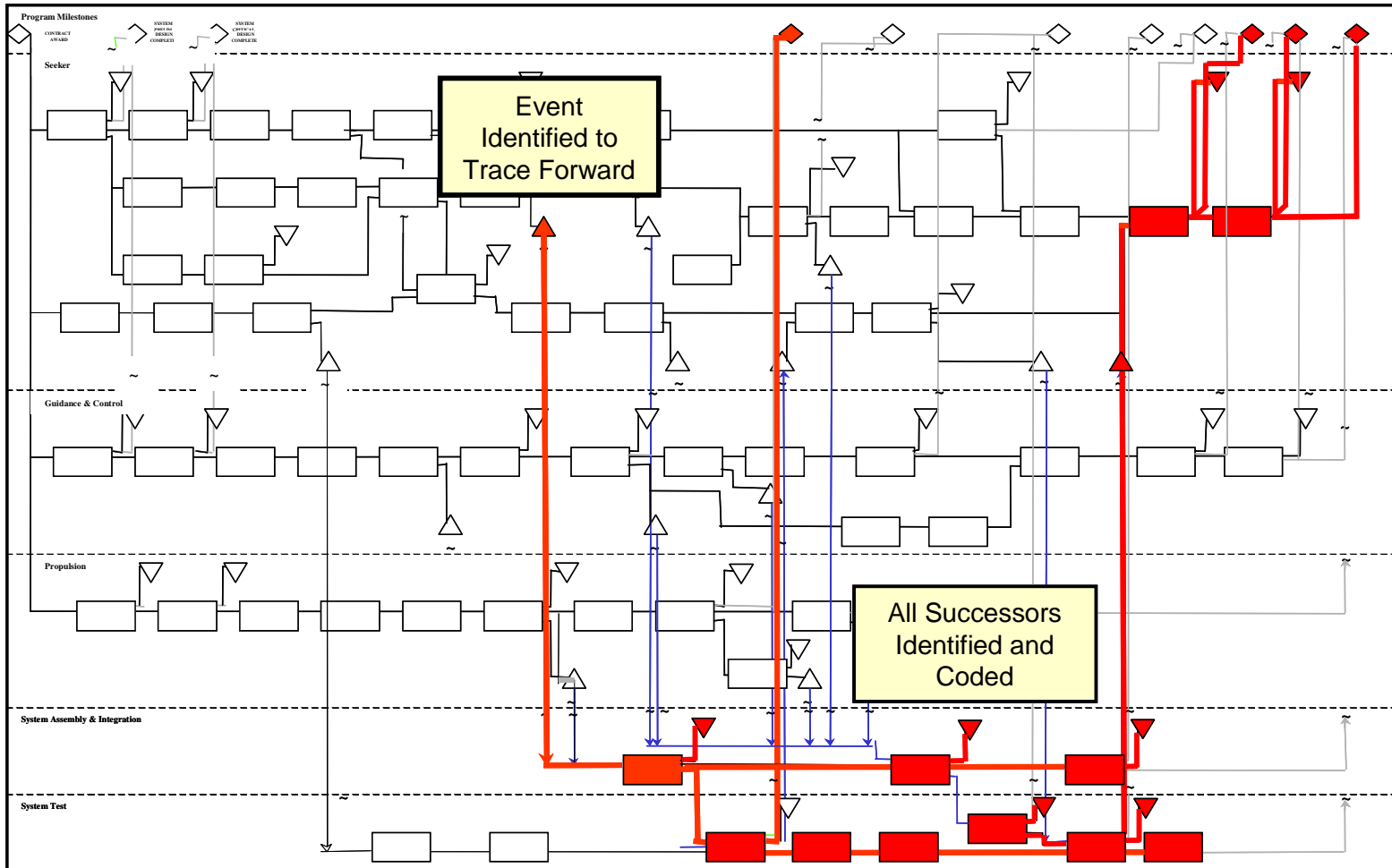

Figure 9

Multiple Events, Last Reference

- Trace forward identifying all successors from a multiple events
- Process codes each successor with the first (in date order) event supported
- Able to review tasks not coded to determine correct link to support an event

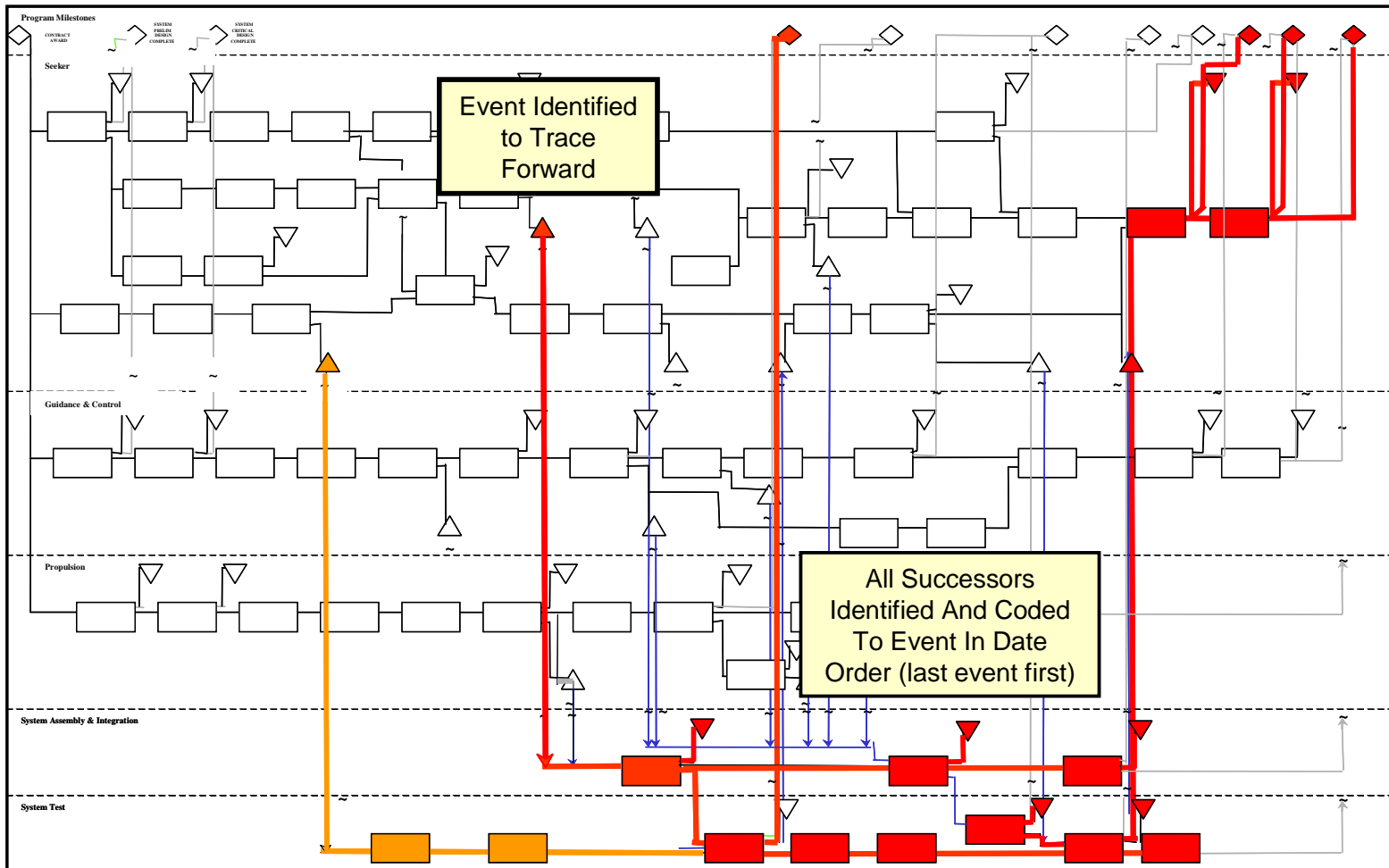

Figure 10

Multiple Events, All References

- Trace forward identifying all successors from a multiple events
- Process codes each successor with the all events supported (comma delimited)
- Able to review tasks not coded to determine correct link to support an event

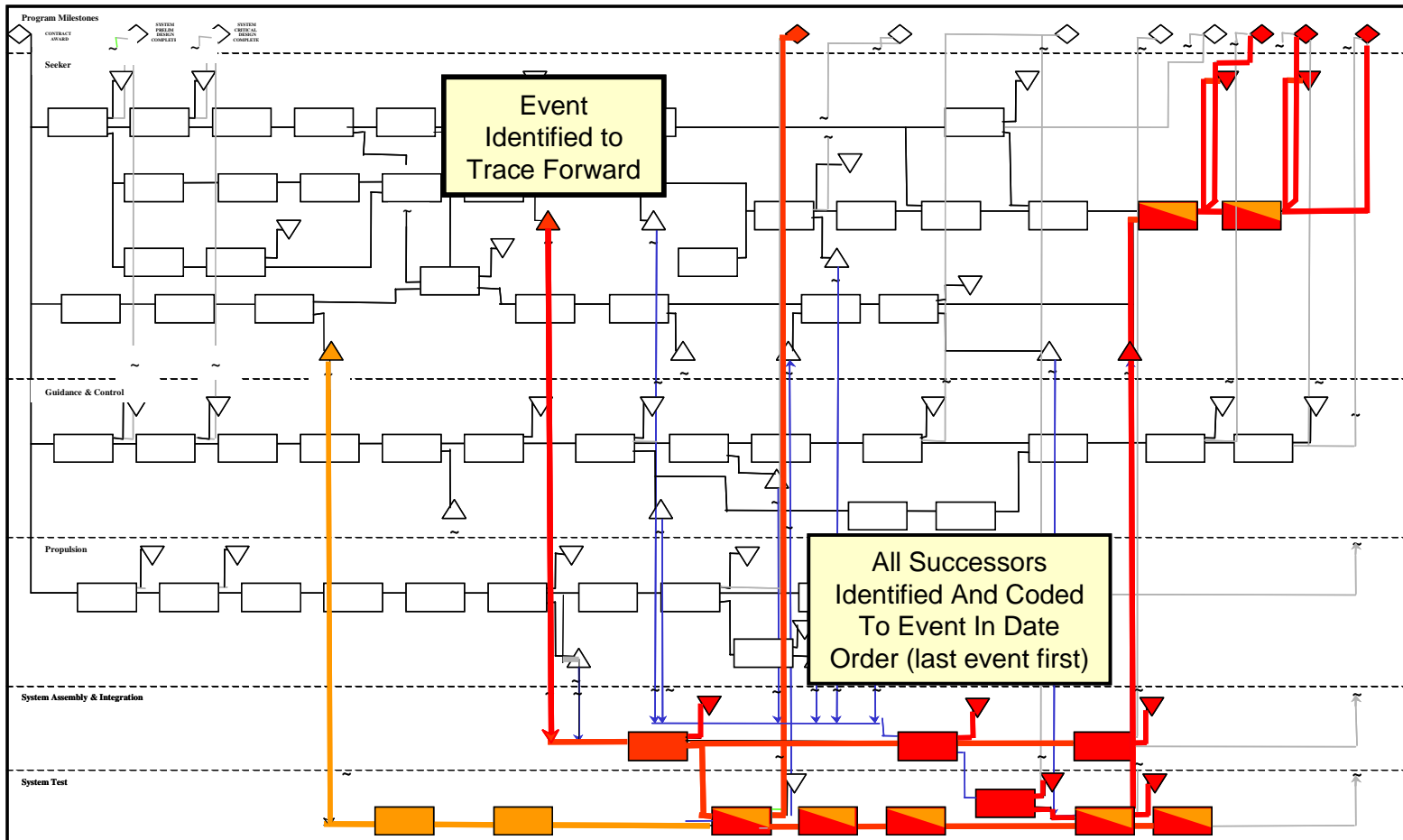

Figure 11

Trace Between

- Trace between to events, identifying all activities linked.
- Codes all the tasks and then invokes a filter to select those tasks

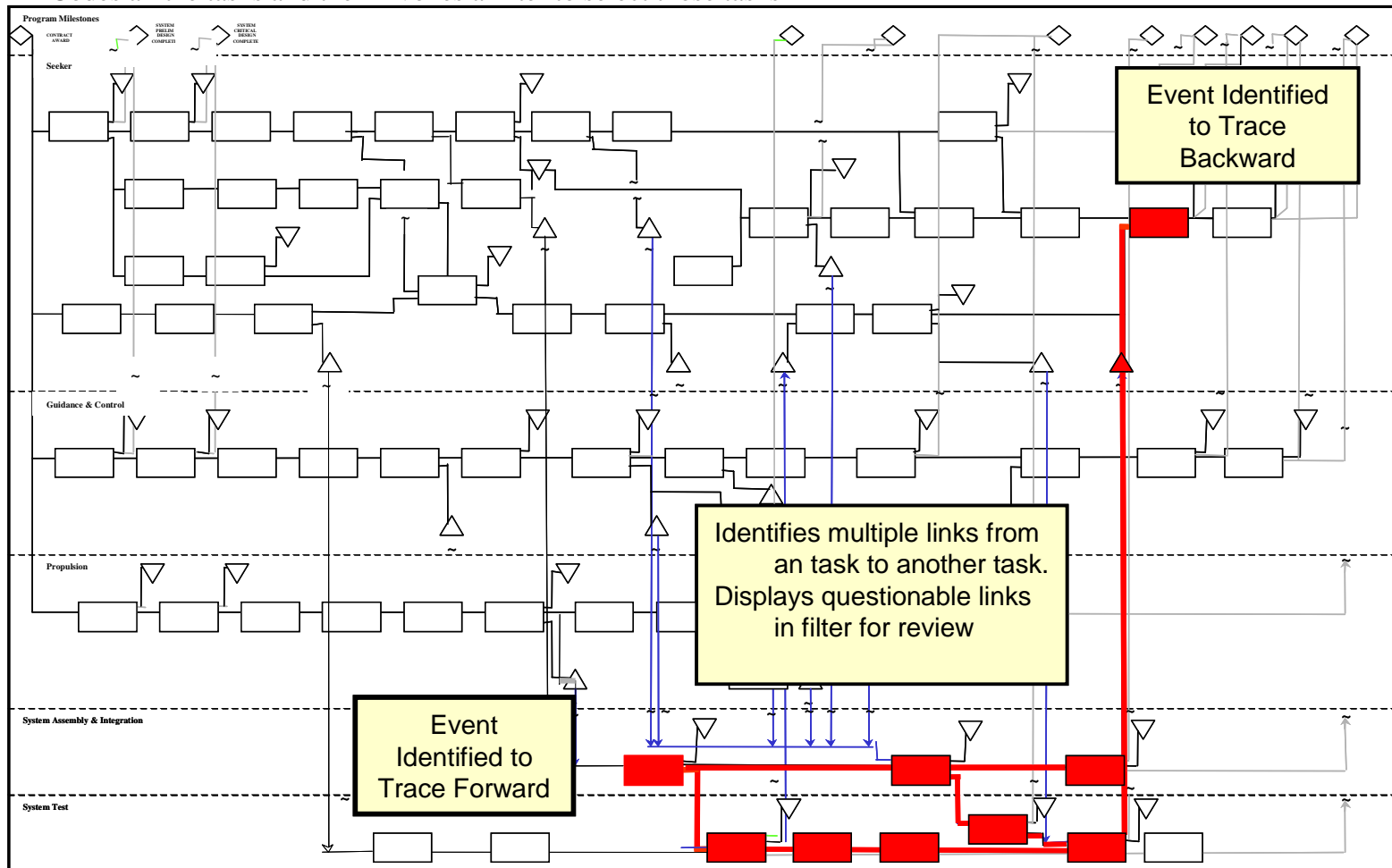

Figure 12

Redundant Links Report

- Identifies multiple links from a task to its immediate successor task(s).
- The reason for this is to eliminate confusing logic.
- The report identifies the task and the successor that has multiple links.
- From the example diagram below you can use the Trace Between to show the links and review and edit.

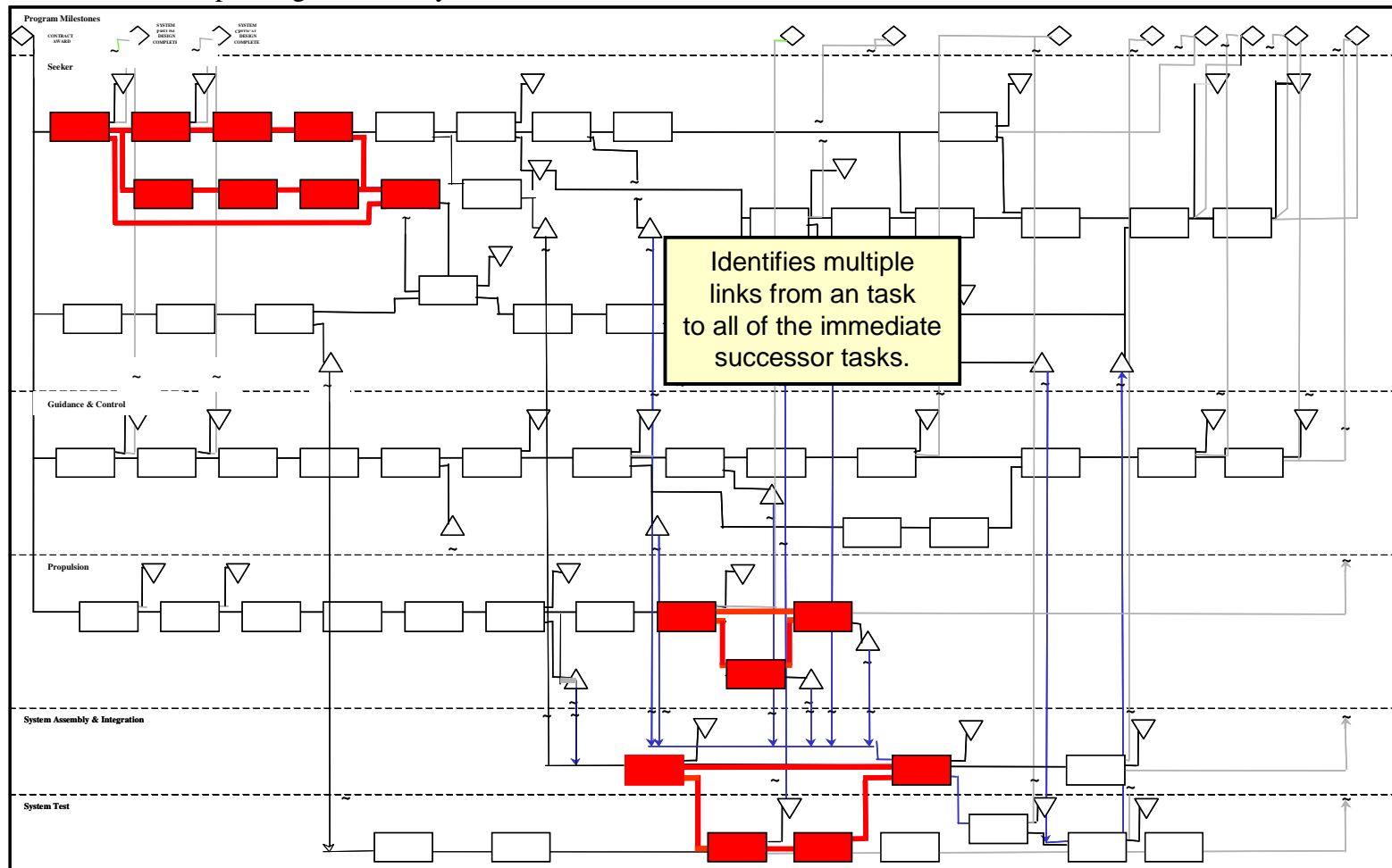

Figure 13